









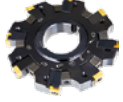

INDEXABLE SLOT MILLS



INDEXABLE SLOT MILLS – NAVIGATOR

SLOT MILLING

	S90SN		S90CN(XN)				
	90°		90°				
	APMX [mm]	4.0 – 14.0	APMX [mm]	14.0 – 30.5			
	DC [mm]	80 – 200	DC [mm]	125 – 315			
Disc		DC = 80 – 200 [mm]		DC = 125 – 315 [mm]			
Shell mill			DC = 63 – 160 [mm]			DC = 125 – 200 [mm]	
Page	510		516				
ISO	P	M	K	P	M	K	
Insert shape							
Inserts	SNHQ 11 SNHQ 12		CNHQ 1005 XNHQ 1205 XNHQ 1606				
No. of cutting edges	4		2				
Deep slot milling 	■		■				
Deep shoulder milling 	▣		▣				
Face milling 	▣		▣				
Rear face milling 	▣		▣				



S90SN

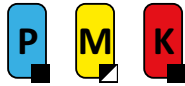

PRAMET

S



Side and Face Disk Milling Cutter

90° side and face cutter utilising SNHQ 11, 12 inserts with APMX (slotting depth) of 10.5 up to 62 mm. Suitable for shoulder, slot, rear side and face milling. Available in arbor or stub arbor style, in range Ø63 up to Ø200 mm. Body treated for longer tool life.

KAPR	90°
CW	4.0 - 14.0 mm

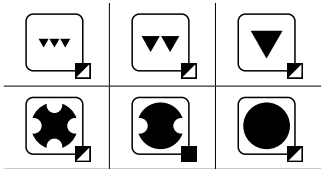
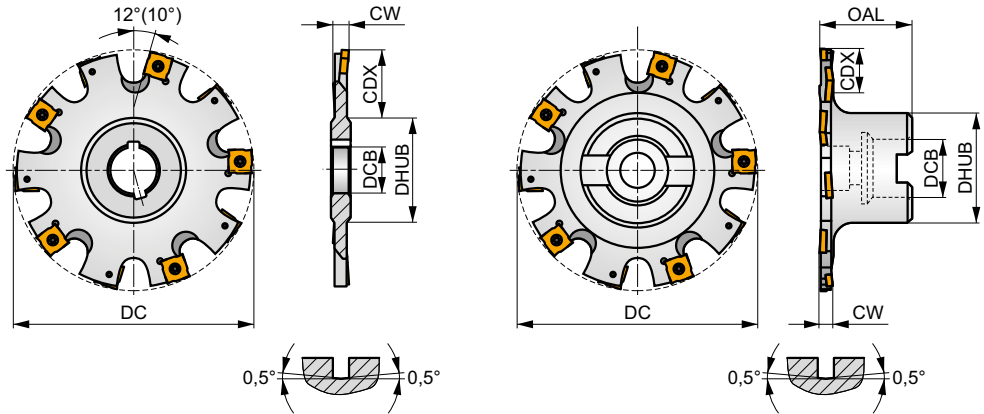
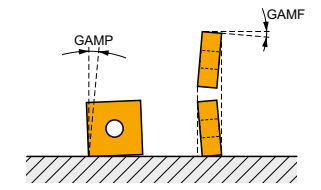

	0.07 - 0.09
	0.07 - 0.09



Product	DC	OAL	DCB	DHUB	CDX	CW	λ	GAMF	GAMP					kg			
	[mm]	[mm]	[mm]	[mm]	[mm]	[mm]	[°]	[°]	[°]								
80F8N-S90SN11N4	80	-	27	42	16	4.00	-	2.5	-0.5	8	-	12300	-	0.23	GI151	DI011	-
80F8N-S90SN11N5	80	-	27	42	16	5.00	-	2.5	-0.5	8	-	12300	-	0.22	GI152	DI019	-
80F8N-S90SN12N6	80	-	27	42	16	6.00	-	2.5	-0.5	8	-	8400	-	0.25	GI153	DI012	-
80F8N-S90SN12N8	80	-	27	42	16	8.00	-	2.5	-0.5	8	-	8400	-	0.28	GI157	DI013	-
100G10N-S90SN12N6	100	-	32	48	24	6.00	-	2.5	-0.5	10	-	7500	-	0.43	GI153	DI012	-
100G10N-S90SN12N8	100	-	32	48	24	8.00	-	2.5	-0.5	10	-	7500	-	0.42	GI157	DI013	-
100G10N-S90SN12N10	100	-	32	48	24	10.00	-	2.5	-0.5	10	-	7500	-	0.46	GI154	DI014	-
100G10N-S90SN12N12	100	-	32	48	24	12.00	-	2.5	-0.5	10	-	7500	-	0.66	GI158	DI015	-
125H12N-S90SN12N6	125	-	40	58	31	6.00	-	2.5	-0.5	12	-	6700	-	0.62	GI153	DI012	-
125H12N-S90SN12N8	125	-	40	58	31	8.00	-	2.5	-0.5	12	-	6700	-	0.73	GI157	DI013	-
125H12N-S90SN12N10	125	-	40	58	31	10.00	-	2.5	-0.5	12	-	6700	-	0.66	GI154	DI014	-
125H12N-S90SN12N12	125	-	40	58	31	12.00	-	2.5	-0.5	12	-	6700	-	0.76	GI158	DI015	-
160H16N-S90SN12N6	160	-	40	58	43	6.00	-	2.5	-0.5	16	-	5900	-	0.86	GI153	DI012	-
160H16N-S90SN12N8	160	-	40	58	43	8.00	-	2.5	-0.5	16	-	5900	-	1.10	GI157	DI013	-
160H16N-S90SN12N10	160	-	40	58	43	10.00	-	2.5	-0.5	16	-	5900	-	1.14	GI154	DI014	-
160H16N-S90SN12N12	160	-	40	58	43	12.00	-	2.5	-0.5	16	-	5900	-	1.30	GI158	DI015	-
160H15N-S90SN12N14	160	-	40	58	43	14.00	-	2.5	-0.5	15	-	5900	-	1.40	GI158	DI015	-
200J18N-S90SN12N6	200	-	50	72	62	6.00	-	2.5	-0.5	18	-	5300	-	1.40	GI153	DI012	-
200J18N-S90SN12N8	200	-	50	72	62	8.00	-	2.5	-0.5	18	-	5300	-	1.78	GI157	DI013	-
200J18N-S90SN12N10	200	-	50	72	62	10.00	-	2.5	-0.5	18	-	5300	-	1.89	GI154	DI014	-
200J18N-S90SN12N12	200	-	50	72	62	12.00	-	2.5	-0.5	18	-	5300	-	2.23	GI158	DI015	-
200J18N-S90SN12N14	200	-	50	72	62	14.00	-	2.5	-0.5	18	-	5300	-	2.67	GI158	DI015	-
63A03R-S90SN11N4	63	40	16	34	10.5	4.00	3	2.5	-0.5	6	-	13900	-	0.39	GI151	DI021	-
63A03R-S90SN11N5	63	40	16	34	10.5	5.00	3	2.5	-0.5	6	-	13900	-	0.36	GI152	DI021	-
63A03R-S90SN12N6	63	40	16	34	10.5	6.00	3	2.5	-0.5	6	-	9500	-	0.37	GI153	DI022	-
80A04R-S90SN11N5	80	40	22	40	17.5	5.00	4	2.5	-0.5	8	-	12300	-	0.48	GI152	DI023	-
80A04R-S90SN12N6	80	40	22	40	17.5	6.00	4	2.5	-0.5	8	-	8400	-	0.50	GI153	DI024	-



Product	DC	OAL	DCB	DHUB	CDX	CW		GAMF	GAMP								
	[mm]	[mm]	[mm]	[mm]	[mm]	[mm]		[°]	[°]								
100A05R-S90SN12N6	100	50	27	48	23.5	6.00	5	2.5	-0.5	10	-	7500	-	0.86	GI153	DI025	-
125B06R-S90SN12N6	125	50	40	56	24	6.00	6	2.5	-0.5	12	-	6700	-	1.20	GI153	DI012	AC003
160B08R-S90SN12N10	160	50	40	70	41	10.00	8	2.5	-0.5	16	-	5900	-	2.03	GI154	DI014	-

GI151	SNHQ 1102..
GI152	SNHQ 1103..
GI153	SNHQ 1203..
GI154	SNHQ 1205..
GI157	SNHQ 1204..
GI158	SNHQ 1207

DI011	US 3504-T09P	3.0	M 3.5	4	D-T07P/T09P	FG-15	-	-
DI012	US 70	5.0	M 4	5	D-T07/T15	FG-15	-	-
DI013	US 71	5.0	M 4	7	D-T07/T15	FG-15	-	-
DI014	US 72	5.0	M 4	9	D-T07/T15	FG-15	-	-
DI015	US 73	5.0	M 4	11	D-T07/T15	FG-15	-	-
DI019	US 3505-T09P	3.0	M 3.5	5	D-T07P/T09P	FG-15	HS 0830	-
DI021	US 3504-T09P	3.0	M 3.5	4	D-T07P/T09P	FG-15	HS 0830	-
DI022	US 70	5.0	M 4	5	D-T07/T15	FG-15	HS 0830	-
DI023	US 3505-T09P	3.0	M 3.5	5	D-T07P/T09P	FG-15	HS 1030	-
DI024	US 70	5.0	M 4	5	D-T07/T15	FG-15	HS 1030	-
DI025	US 70	5.0	M 4	5	D-T07/T15	FG-15	HS 1230	-

AC003	KS 2040	K.FMH40



SNHQ AZ



	IC [mm]	D1 [mm]	W1 [mm]
1102	11.000	4.30	2.300
1103	11.000	4.30	2.700
1203	12.700	5.00	3.200
1204	12.700	5.00	4.500
1205	12.700	5.00	5.400
1207	12.700	5.00	7.000

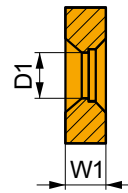
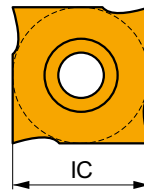

Suitability and starting values for cutting speed (vc), feed (f) and depth of cut (ap). Refer to our Machining Calculator app for further calculations.

Product	RE [mm]	P			M			K			N			S			H		
		vc [m/min]	f [mm/tooth]	ap [mm]	vc [m/min]	f [mm/tooth]	ap [mm]	vc [m/min]	f [mm/tooth]	ap [mm]	vc [m/min]	f [mm/tooth]	ap [mm]	vc [m/min]	f [mm/tooth]	ap [mm]	vc [m/min]	f [mm/tooth]	ap [mm]

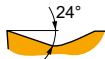
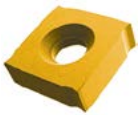

EN geometry with special design for slot milling.

SNHQ 1203AZEN	8215	-	415	0.10	-	245	0.10	-	390	0.10	-	-	-	-	-	-	-	-
	M8340	-	370	0.10	-	220	0.10	-	350	0.10	-	-	-	-	-	-	-	-
SNHQ 1204AZEN	8215	-	405	0.10	-	240	0.10	-	380	0.10	-	-	-	-	-	-	-	-
	M8340	-	355	0.10	-	210	0.10	-	335	0.10	-	-	-	-	-	-	-	-
SNHQ 1205AZEN	8215	-	390	0.10	-	230	0.10	-	370	0.10	-	-	-	-	-	-	-	-
	M8340	-	345	0.10	-	205	0.10	-	325	0.10	-	-	-	-	-	-	-	-
SNHQ 1207AZEN	8215	-	380	0.10	-	225	0.10	-	360	0.10	-	-	-	-	-	-	-	-
	M8340	-	335	0.10	-	200	0.10	-	315	0.10	-	-	-	-	-	-	-	-

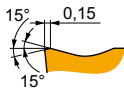
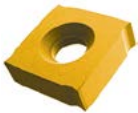

TN geometry with special design for slot milling.

SNHQ 1102AZTN	M8330	-	365	0.20	-	215	0.18	-	345	0.20	-	-	-	-	-	-	-	-
	M8340	-	335	0.20	-	200	0.18	-	315	0.20	-	-	-	-	-	-	-	-
SNHQ 1103AZTN	M8330	-	345	0.20	-	205	0.18	-	325	0.20	-	-	-	-	-	-	-	-
	M8340	-	315	0.20	-	185	0.18	-	295	0.20	-	-	-	-	-	-	-	-

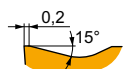
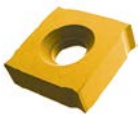

TN geometry with special design for slot milling.

SNHQ 1203AZTN	M8330	-	345	0.20	-	205	0.18	-	325	0.20	-	-	-	-	-	-	-	-
	M8340	-	315	0.20	-	185	0.18	-	295	0.20	-	-	-	-	-	-	-	-
SNHQ 1204AZTN	M8330	-	335	0.20	-	200	0.20	-	315	0.20	-	-	-	-	-	-	-	-
	M8340	-	300	0.20	-	180	0.20	-	285	0.20	-	-	-	-	-	-	-	-
SNHQ 1205AZTN	M8330	-	330	0.20	-	195	0.20	-	310	0.20	-	-	-	-	-	-	-	-
	M8340	-	295	0.20	-	175	0.20	-	280	0.20	-	-	-	-	-	-	-	-
SNHQ 1207AZTN	M8330	-	320	0.20	-	190	0.20	-	300	0.20	-	-	-	-	-	-	-	-
	M8340	-	290	0.20	-	170	0.20	-	275	0.20	-	-	-	-	-	-	-	-



SNHQ TRL

	IC	D1	L	W1
	[mm]	[mm]	[mm]	[mm]
1203	12.700	5.00	12.70	3.200
1204	12.700	5.00	12.70	4.500
1205	12.700	5.00	12.70	5.400
1207	12.700	5.00	12.70	7.000

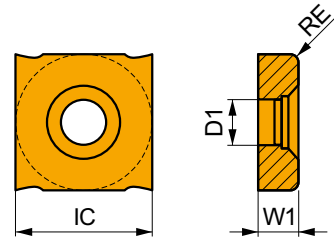

Suitability and starting values for cutting speed (vc), feed (f) and depth of cut (ap). Refer to our Machining Calculator app for further calculations.

Product	RE	P			M			K			N			S			H		
		vc	f	ap	vc	f	ap	vc	f	ap	vc	f	ap	vc	f	ap	vc	f	ap
	[mm]	[m/min]	[mm/tooth]	[mm]	[m/min]	[mm/tooth]	[mm]	[m/min]	[mm/tooth]	[mm]	[m/min]	[mm/tooth]	[mm]	[m/min]	[mm/tooth]	[mm]	[m/min]	[mm/tooth]	[mm]

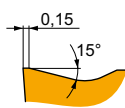
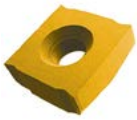

TRL geometry with special design for slot milling.

SNHQ 120305TRL	M8340	0.5	230	0.20	—	135	0.18	—	215	0.20	—	—	—	—	—	—	—	—	—
SNHQ 120310TRL	M8340	1.0	285	0.20	—	170	0.18	—	270	0.20	—	—	—	—	—	—	—	—	—
SNHQ 120315TRL	M8340	1.5	300	0.20	—	180	0.18	—	285	0.20	—	—	—	—	—	—	—	—	—
SNHQ 120405TRL	M8340	0.5	220	0.20	—	130	0.20	—	205	0.20	—	—	—	—	—	—	—	—	—
SNHQ 120410TRL	M8340	1.0	275	0.20	—	165	0.20	—	260	0.20	—	—	—	—	—	—	—	—	—
SNHQ 120415TRL	M8340	1.5	290	0.20	—	170	0.20	—	275	0.20	—	—	—	—	—	—	—	—	—
SNHQ 120505TRL	M8340	0.5	215	0.20	—	125	0.20	—	200	0.20	—	—	—	—	—	—	—	—	—
SNHQ 120510TRL	M8340	1.0	270	0.20	—	160	0.20	—	255	0.20	—	—	—	—	—	—	—	—	—
SNHQ 120515TRL	M8340	1.5	280	0.20	—	165	0.20	—	265	0.20	—	—	—	—	—	—	—	—	—
SNHQ 120705TRL	M8340	0.5	210	0.20	—	125	0.20	—	195	0.20	—	—	—	—	—	—	—	—	—
SNHQ 120710TRL	M8340	1.0	265	0.20	—	155	0.20	—	250	0.20	—	—	—	—	—	—	—	—	—
SNHQ 120715TRL	M8340	1.5	275	0.20	—	165	0.20	—	260	0.20	—	—	—	—	—	—	—	—	—



a_e DC	0.05	0.10	0.15	0.20	0.25	0.30	0.40	0.50	0.60	0.70	0.75	0.80	0.90	1.00
X.V	1.48	1.35	1.27	1.22	1.19	1.16	1.11	1.08	1.05	1.03	1.00	1.00	1.00	1.00

	SNHQ AZEN	SNHQ AZTN	SNHQ 12TRL
RE	-	-	0.5-1.5
BS	-	-	-

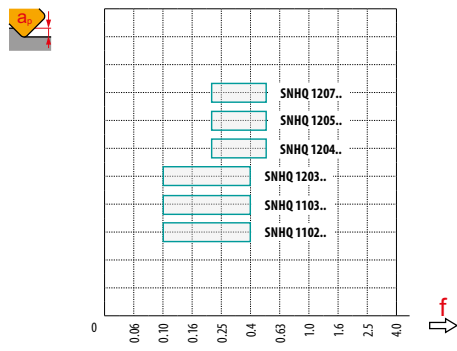



















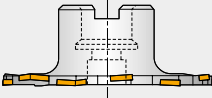

	DC		GDX	$a_{e\max}$
	80	4	16	16
	100	5	24	24
	125	6	31	31
	160	5	43	43
	200	9	62	62
	63	3	10.5	63
	80	4	17.5	80
	100	5	23.5	100
	125	6	24	125
	160	8	41	160



	a_e	5		10		15		20		25	
	DC	f_{\min}	f_{\max}	f_{\min}	f_{\max}	f_{\min}	f_{\max}	f_{\min}	f_{\max}	f_{\min}	f_{\max}
	80	0.28	0.36	0.20	0.26	0.17	0.21	-	-	-	-
	100	0.32	0.41	0.23	0.29	0.19	0.24	0.16	0.21	-	-
	125	0.35	0.45	0.25	0.32	0.21	0.27	0.18	0.23	0.16	0.21
	160	0.40	0.51	0.28	0.36	0.23	0.30	0.20	0.26	0.18	0.23
	200	0.44	0.57	0.32	0.41	0.26	0.33	0.23	0.29	0.20	0.26
	63	0.25	0.32	0.18	0.23	0.15	0.19	0.13	0.17	0.12	0.15
	80	0.28	0.36	0.20	0.26	0.17	0.21	0.15	0.19	0.13	0.17
	100	0.32	0.41	0.23	0.29	0.19	0.24	0.16	0.21	0.15	0.19
	125	0.35	0.45	0.25	0.32	0.21	0.27	0.18	0.23	0.16	0.21
	160	0.40	0.51	0.28	0.36	0.23	0.30	0.20	0.26	0.18	0.23

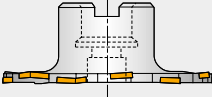

	a _e	32		40		50		63		80	
		f_{min} 	f_{max} 	f_{min} 	f_{max} 	f_{min} 	f_{max} 	f_{min} 	f_{max} 	f_{min} 	f_{max} 
	80	-	-	-	-	-	-	-	-	-	-
	100	-	-	-	-	-	-	-	-	-	-
	125	-	-	-	-	-	-	-	-	-	-
	160	0.16	0.21	0.15	0.19	-	-	-	-	-	-
	200	0.18	0.23	0.16	0.21	0.15	0.19	-	-	-	-
	63	0.11	0.14	0.10	0.13	0.10	0.12	0.10	0.11	-	-
	80	0.12	0.15	0.11	0.14	0.10	0.13	0.10	0.12	0.10	0.11
	100	0.13	0.17	0.12	0.15	0.11	0.14	0.10	0.13	0.10	0.12
	125	0.15	0.19	0.13	0.17	0.12	0.15	0.11	0.14	0.10	0.13
	160	0.16	0.21	0.15	0.19	0.13	0.17	0.12	0.16	0.11	0.14

	a _e	100		125		160	
		f_{min} 	f_{max} 	f_{min} 	f_{max} 	f_{min} 	f_{max} 
	80	-	-	-	-	-	-
	100	-	-	-	-	-	-
	125	-	-	-	-	-	-
	160	-	-	-	-	-	-
	200	-	-	-	-	-	-
	63	-	-	-	-	-	-
	80	-	-	-	-	-	-
	100	0.10	0.11	-	-	-	-
	125	0.10	0.12	0.10	0.11	-	-
	160	0.10	0.13	0.10	0.12	0.10	0.11



S90CN(XN)



PRAMET

S



Side and Face Disk Milling Cutter with Adjustable Width

90° side and face cutter utilising CNHQ 10 and XNHQ 12, 16 inserts with APMX (slotting depth) of 25 up to 110 mm. Suitable for shoulder, slot, rear side and face milling. Available in arbor or stub arbor style, in range Ø125 up to Ø315 mm. Body treated for longer tool life.

KAPR	90°
CW	14.0 - 30.5 mm

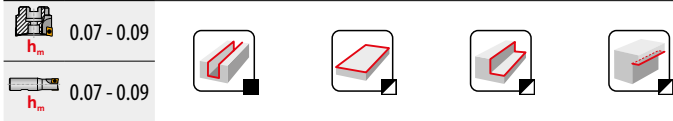
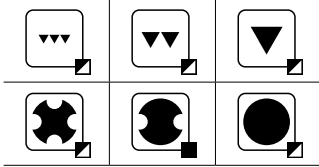
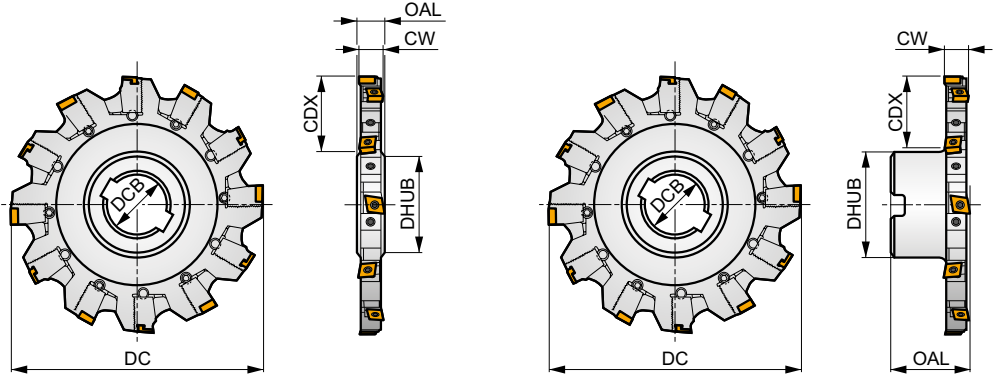
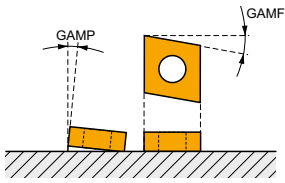

Product	DC	OAL	DCB	DHUB	CDX	CW	GAMF	GAMP	X	Z	max.	kg	G	D	AC		
	[mm]	[mm]	[mm]	[mm]	[mm]	[mm]	[°]	[°]									
125H04N-S90CN10N18	125	18	40	56	34	14.0 ÷ 18.5	-10	4	4	8	-	7800	-	1.50	GI195	DI051	-
160H06N-S90CN10N18	160	18	40	56	50	14.0 ÷ 18.5	-8	4	6	12	-	6900	-	1.80	GI195	DI052	-
160H05N-S90XN12N24	160	24	40	56	50	19.0 ÷ 24.3	-8	5	5	10	-	5200	-	2.50	GI196	DI056	-
200J07N-S90CN10N18	200	18	50	71	60	14.0 ÷ 18.5	-8	4	7	14	-	6100	-	2.85	GI195	DI053	-
200J06N-S90XN12N24	200	24	50	71	60	19.0 ÷ 24.3	-8	5	6	12	-	4700	-	3.60	GI196	DI057	-
200J06N-S90XN16N30	200	30	50	71	60	24.5 ÷ 30.5	-9	5	6	12	-	4000	-	6.00	GI197	DI060	-
250J09N-S90CN10N18	250	18	50	71	85	14.0 ÷ 18.5	-8	4	9	18	-	5500	-	5.30	GI195	DI054	-
250J08N-S90XN12N24	250	24	50	71	85	19.0 ÷ 24.3	-8	5	8	16	-	4200	-	7.50	GI196	DI058	-
250J08N-S90XN16N30	250	30	50	71	85	24.5 ÷ 30.5	-8	5	8	16	-	3600	-	8.00	GI197	DI061	-
315J12N-S90CN10N18	315	18	50	71	110	14.0 ÷ 18.5	-8	4	12	24	-	4900	-	7.80	GI195	DI055	-
315J10N-S90XN12N24	315	24	50	71	110	19.0 ÷ 24.3	-8	5	10	20	-	3700	-	11.00	GI196	DI059	-
315K10N-S90XN16N30	315	30	60	85	110	24.5 ÷ 30.5	-8	5	10	20	-	3200	-	13.00	GI197	DI062	-
125B04R-S90CN10N18	125	50	40	70	25	14.0 ÷ 18.5	-10	4	4	8	-	7800	-	1.65	GI195	DI071	AC003
160B06R-S90CN10N18	160	50	40	70	44	14.0 ÷ 18.5	-8	5	6	12	-	6900	-	2.55	GI195	DI072	-
160B05R-S90XN12N24	160	50	40	70	44	19.0 ÷ 24.3	-8	5	5	10	-	5200	-	2.90	GI196	DI074	-
200C06R-S90XN12N24	200	50	40	90	52	19.0 ÷ 24.3	-8	5	6	12	-	6100	-	4.70	GI196	DI075	-
200C06R-S90XN16N30	200	50	60	130	34	24.5 ÷ 30.5	-9	5	6	12	-	4700	-	5.95	GI197	DI076	-
200C07R-S90CN10N18	200	50	40	90	52	14.0 ÷ 18.5	-8	4	7	14	-	6100	-	4.05	GI195	DI073	-



GI195	CNHQ 1005..
GI196	XNHQ 1205..
GI197	XNHQ 1606..



DI051	125H04N-S-14-08	KL-1418-CN10	KR-1418-CN10	KS 613F	DS 6018F	SDRT20	SS 6005-T09P	SDR T09	US 4011-T15P	3.5	M 4	10.6	SDRT15P	-
DI052	160H06N-S-14-12	KL-1418-CN10	KR-1418-CN10	KS 613F	DS 6018F	SDRT20	SS 6005-T09P	SDR T09	US 4011-T15P	3.5	M 4	10.6	SDRT15P	-
DI053	200J07N-S-14-14	KL-1418-CN10	KR-1418-CN10	KS 613F	DS 6018F	SDRT20	SS 6005-T09P	SDR T09	US 4011-T15P	3.5	M 4	10.6	SDRT15P	-
DI054	250J09N-S-14-18	KL-1418-CN10	KR-1418-CN10	KS 613F	DS 6018F	SDRT20	SS 6005-T09P	SDR T09	US 4011-T15P	3.5	M 4	10.6	SDRT15P	-
DI055	315J12N-S-14-24	KL-1418-CN10	KR-1418-CN10	KS 613F	DS 6018F	SDRT20	SS 6005-T09P	SDR T09	US 4011-T15P	3.5	M 4	10.6	SDRT15P	-
DI056	160H05N-S-19-10	KL-1924-XN12	KR-1924-XN12	KS 617M	DS 6500	-	SS 6005-T09P	SDR T09	US 4011-T15P	3.5	M 4	10.6	SDRT15P	HXX 4
DI057	200J06N-S-19-12	KL-1924-XN12	KR-1924-XN12	KS 617M	DS 6500	-	SS 6005-T09P	SDR T09	US 4011-T15P	3.5	M 4	10.6	SDRT15P	HXX 4
DI058	250J08N-S-19-16	KL-1924-XN12	KR-1924-XN12	KS 617M	DS 6500	-	SS 6005-T09P	SDR T09	US 4011-T15P	3.5	M 4	10.6	SDRT15P	HXX 4
DI059	315J10N-S-19-20	KL-1924-XN12	KR-1924-XN12	KS 617M	DS 6500	-	SS 6005-T09P	SDR T09	US 4011-T15P	3.5	M 4	10.6	SDRT15P	HXX 4
DI060	200J06N-S-25-12	KL-2530-XN16	KR-2530-XN16	KS 623M	DS 6500	-	SS 6005-T09P	SDR T09	US 4011-T15P	3.5	M 4	10.6	SDRT15P	HXX 4
DI061	250J08N-S-25-16	KL-2530-XN16	KR-2530-XN16	KS 623M	DS 6500	-	SS 6005-T09P	SDR T09	US 4011-T15P	3.5	M 4	10.6	SDRT15P	HXX 4
DI062	315K10N-S-25-20	KL-2530-XN16	KR-2530-XN16	KS 623M	DS 6500	-	SS 6005-T09P	SDR T09	US 4011-T15P	3.5	M 4	10.6	SDRT15P	HXX 4
DI071	125B04R-S-14-08	KL-1418-CN10	KR-1418-CN10	KS 613F	DS 6018F	SDRT20	SS 6005-T09P	SDR T09	US 4011-T15P	3.5	M 4	10.6	SDRT15P	-
DI072	160B06R-S-14-12	KL-1418-CN10	KR-1418-CN10	KS 613F	DS 6018F	SDRT20	SS 6005-T09P	SDR T09	US 4011-T15P	3.5	M 4	10.6	SDRT15P	-
DI073	200C07R-S-14-14	KL-1418-CN10	KR-1418-CN10	KS 613F	DS 6018F	SDRT20	SS 6005-T09P	SDR T09	US 4011-T15P	3.5	M 4	10.6	SDRT15P	-
DI074	160B05R-S-19-10	KL-1924-XN12	KR-1924-XN12	KS 617M	DS 6500	-	SS 6005-T09P	SDR T09	US 4011-T15P	3.5	M 4	10.6	SDRT15P	HXX 4
DI075	200C06R-S-19-12	KL-1924-XN12	KR-1924-XN12	KS 617M	DS 6500	-	SS 6005-T09P	SDR T09	US 4011-T15P	3.5	M 4	10.6	SDRT15P	HXX 4
DI076	200C06R-S-25-12	KL-2530-XN16	KR-2530-XN16	KS 623M	DS 6500	-	SS 6005-T09P	SDR T09	US 4011-T15P	3.5	M 4	10.6	SDRT15P	HXX 4



AC003	KS 2040	K.FMH40
-------	---------	---------



CNHQ

PRAMET

	BCH	IC	D1	L	W1
	[mm]	[mm]	[mm]	[mm]	[mm]
1005	0.50	10.000	4.70	10.00	5.400

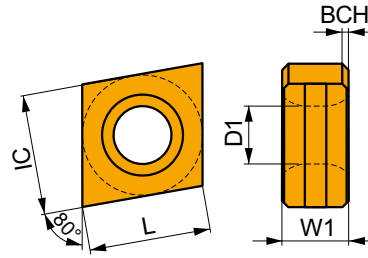

Suitability and starting values for cutting speed (vc), feed (f) and depth of cut (ap). Refer to our Machining Calculator app for further calculations.

Product	RE	P			M			K			N			S			H		
		vc	f	ap	vc	f	ap	vc	f	ap	vc	f	ap	vc	f	ap	vc	f	ap
	[mm]	[m/min]	[mm/tooth]	[mm]	[m/min]	[mm/tooth]	[mm]	[m/min]	[mm/tooth]	[mm]	[m/min]	[mm/tooth]	[mm]	[m/min]	[mm/tooth]	[mm]	[m/min]	[mm/tooth]	[mm]

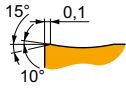

Special design for slot milling with light to heavy cutting conditions.

CNHQ 1005AZTN	M8330	-	310	0.15	-	185	0.14	-	290	0.15	-	-	-	-	-	-	-	-	-
	M8340	-	280	0.15	-	165	0.14	-	265	0.15	-	-	-	-	-	-	-	-	-

XNHQ

PRAMET

	BCH	IC	D1	L	W1
	[mm]	[mm]	[mm]	[mm]	[mm]
1205	0.50	10.000	4.70	12.70	5.400
1606	0.50	12.000	5.90	16.00	6.400

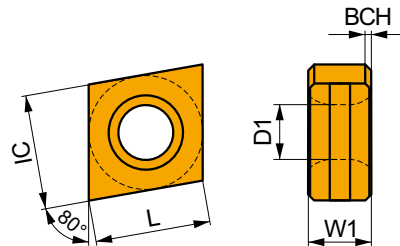

Suitability and starting values for cutting speed (vc), feed (f) and depth of cut (ap). Refer to our Machining Calculator app for further calculations.

Product	RE	P			M			K			N			S			H		
		vc	f	ap	vc	f	ap	vc	f	ap	vc	f	ap	vc	f	ap	vc	f	ap
	[mm]	[m/min]	[mm/tooth]	[mm]	[m/min]	[mm/tooth]	[mm]	[m/min]	[mm/tooth]	[mm]	[m/min]	[mm/tooth]	[mm]	[m/min]	[mm/tooth]	[mm]	[m/min]	[mm/tooth]	[mm]

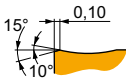

Special design for slot milling.

XNHQ 1205AZTN	M8330	-	310	0.15	-	185	0.14	-	290	0.15	-	-	-	-	-	-	-	-	-
	M8340	-	275	0.15	-	165	0.14	-	260	0.15	-	-	-	-	-	-	-	-	-
XNHQ 1606AZTN	M8330	-	300	0.15	-	180	0.14	-	285	0.15	-	-	-	-	-	-	-	-	-
	M8340	-	270	0.15	-	160	0.14	-	255	0.15	-	-	-	-	-	-	-	-	-



a_e DC	0.05	0.10	0.15	0.20	0.25	0.30	0.40	0.50	0.60	0.70	0.75	0.80	0.90	1.00
	1.48	1.35	1.27	1.22	1.19	1.16	1.11	1.08	1.05	1.03	1.00	1.00	1.00	1.00

	CNHQ 10	XNHQ 12	XNHQ 16
	-	-	-

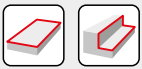
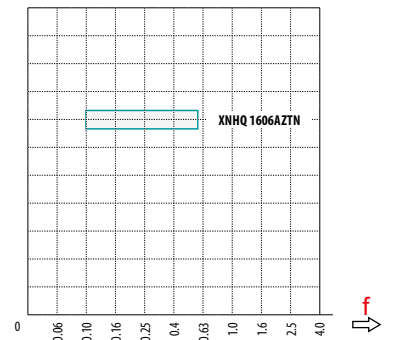
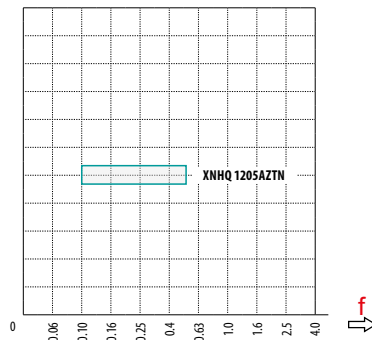
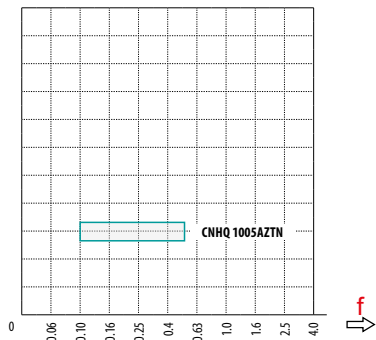























	125	4	34	34
	160	6	50	50
	200	7	60	60
	250	9	85	85
	315	12	110	110
	125	4	25	125
	160	6	44	160
	200	7	52	200



	a_e	5		10		15		20		25	
		f_{min}	f_{max}	f_{min}	f_{max}	f_{min}	f_{max}	f_{min}	f_{max}	f_{min}	f_{max}
	125	0.35	0.45	0.25	0.32	0.21	0.27	0.18	0.23	0.16	0.21
	160	0.40	0.51	0.28	0.36	0.23	0.30	0.20	0.26	0.18	0.23
	200	0.44	0.57	0.32	0.41	0.26	0.33	0.23	0.29	0.20	0.26
	250	0.50	0.64	0.35	0.45	0.29	0.37	0.25	0.32	0.23	0.29
	315	0.56	0.72	0.39	0.51	0.32	0.42	0.28	0.36	0.25	0.32
	125	0.35	0.45	0.25	0.32	0.21	0.27	0.18	0.23	0.16	0.21
	160	0.40	0.51	0.28	0.36	0.23	0.30	0.20	0.26	0.18	0.23
	200	0.44	0.57	0.32	0.41	0.26	0.33	0.23	0.29	0.20	0.26

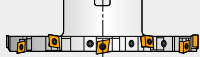

	a_e	32		40		50		63		80	
		f_{min} 	f_{max} 	f_{min} 	f_{max} 	f_{min} 	f_{max} 	f_{min} 	f_{max} 	f_{min} 	f_{max} 
	125	0.15	0.19	–	–	–	–	–	–	–	–
	160	0.16	0.21	0.15	0.19	–	–	–	–	–	–
	200	0.18	0.23	0.16	0.21	0.15	0.19	–	–	–	–
	250	0.20	0.26	0.18	0.23	0.16	0.21	0.15	0.19	0.13	0.17
	315	0.22	0.29	0.20	0.26	0.18	0.23	0.16	0.21	0.15	0.19
	125	0.15	0.19	0.13	0.17	0.12	0.15	0.11	0.14	0.10	0.13
	160	0.16	0.21	0.15	0.19	0.13	0.17	0.12	0.16	0.11	0.14
	200	0.18	0.23	0.16	0.21	0.15	0.19	0.13	0.17	0.12	0.15

	a_e	100		125		160		200	
		f_{min} 	f_{max} 	f_{min} 	f_{max} 	f_{min} 	f_{max} 	f_{min} 	f_{max} 
	125	–	–	–	–	–	–	–	–
	160	–	–	–	–	–	–	–	–
	200	–	–	–	–	–	–	–	–
	250	–	–	–	–	–	–	–	–
	315	0.13	0.17	–	–	–	–	–	–
	125	0.10	0.12	0.10	0.11	–	–	–	–
	160	0.10	0.13	0.10	0.12	0.10	0.11	–	–
	200	0.11	0.14	0.10	0.13	0.10	0.12	0.10	0.11