

HSS

DIN

SEGHE CIRCOLARI IN HSS
CIRCULAR SAW BLADES IN HSS
METALLKREISSÄGEBLÄTTER AUS HSS

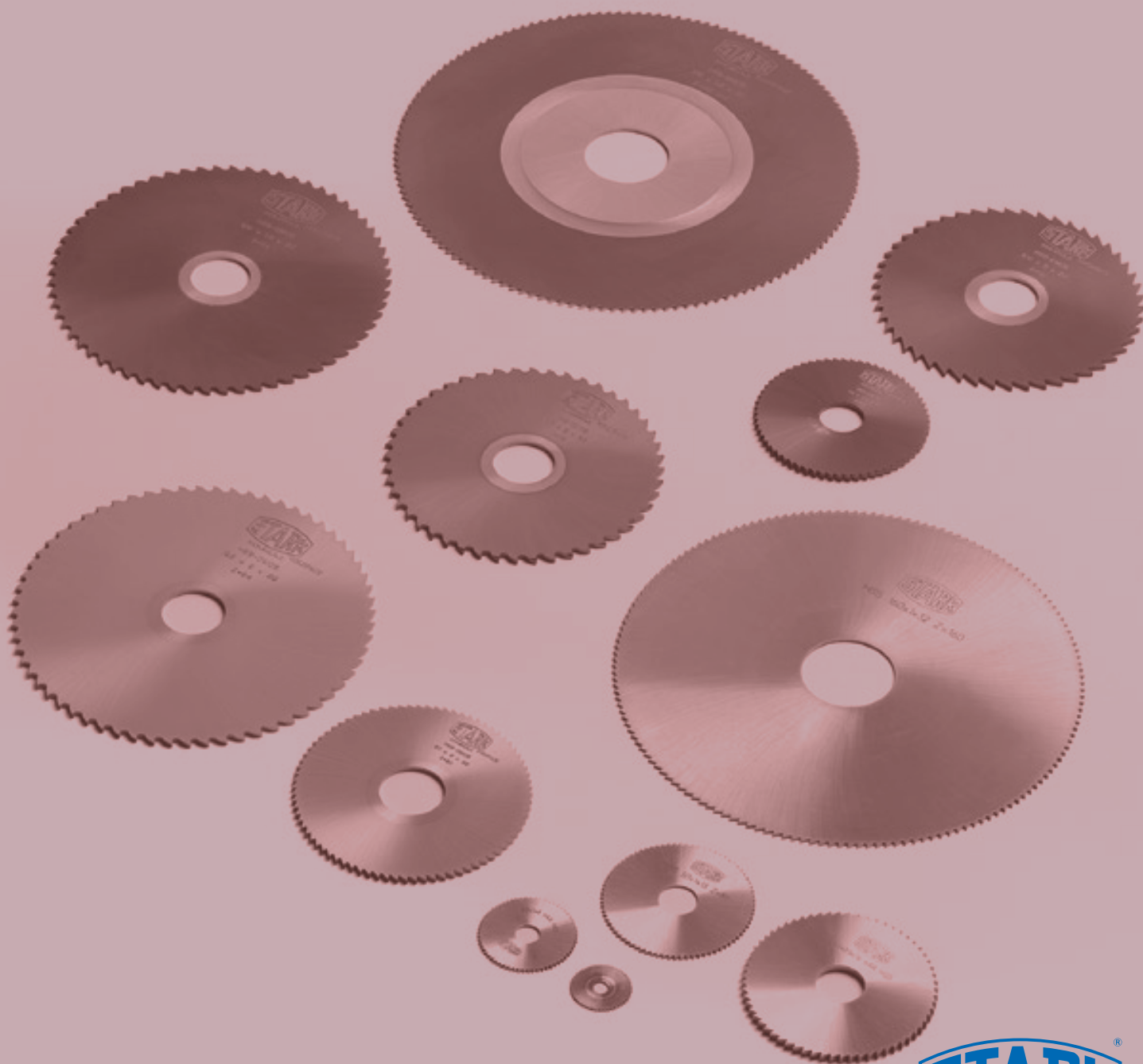

STARK[®]
quality by choice



SEGHE CIRCOLARI DIN IN HSS
 DIN CIRCULAR SAW BLADES IN HSS
 DIN METALLKREISSÄGEBLÄTTER AUS HSS

DIN 1837	A	Ø [mm]	20	25	32	40	50	63	80	100	125	160	200	250	315
		Mozzo / Hub / Nabe [dt]	-	-	-	-	-	-	36	40	40	63	63	63	80
		Foro / Bore / Bohrung [d]	5	8	8	10	13	13	22	22	22	32	32	32	40
		Spessore Thickness Stärke B [mm]	[Z]	[Z]	[Z]	[Z]	[Z]	[Z]	[Z]	[Z]	[Z]	[Z]	[Z]	[Z]	[Z]
		0,20	80 A	80 A	100 A	128 A	128 A								
		0,25	64 A	80 A	100 A	100 A	128 A	160 A							
		0,30	64 A	80 A	80 A	100 A	128 A	128 A	160 A						
		0,40	64 A	64 A	80 A	100 A	100 A	128 A	160 A						
		0,50	48 A	64 A	80 A	80 A	100 A	128 A	128 A	160 A					
		0,60	48 A	64 A	64 A	80 A	100 A	100 A	128 A	160 A	160 A				
		0,80	48 A	48 A	64 A	80 A	80 A	100 A	128 A	128 A	160 A				
		1,00	40 A	48 A	64 A	64 A	80 A	100 A	100 A	128 A	160 A	160 A	200 A		
		1,20	40 A	48 A	48 A	64 A	80 A	80 A	100 A	128 A	128 A	160 A	200 A		
		1,60	40 A	40 A	48 A	64 A	64 A	80 A	100 A	100 A	128 A	160 A	160 A	200 A	
		2,00	32 A	40 A	48 A	48 A	64 A	80 A	80 A	100 A	128 A	128 A	160 A	200 A	
		2,50	32 A	40 A	40 A	48 A	64 A	64 A	80 A	100 A	100 A	128 A	160 A	160 A	200 A
		3,00	32 A	32 A	40 A	48 A	48 A	64 A	80 A	80 A	100 A	128 A	128 A	160 A	200 A
		4,00	24 A	32 A	40 A	40 A	48 A	64 A	64 A	80 A	100 A	100 A	128 A	160 A	160 A
		5,00	24 A	32 A	32 A	40 A	48 A	48 A	64 A	80 A	80 A	100 A	128 A	128 A	160 A
		6,00	24 A	24 A	32 A	40 A	40 A	48 A	64 A	64 A	80 A	100 A	100 A	128 A	160 A

DIN 1838	B	Ø [mm]	50	63	80	100	125	160	200	250	315
		Mozzo / Hub / Nabe [dt]	-	-	36	40	40	63	63	63	80
		Foro / Bore / Bohrung [d]	13	16	22	22	22	32	32	32	40
		Spessore Thickness Stärke B [mm]	[Z]	[Z]	[Z]	[Z]	[Z]	[Z]	[Z]	[Z]	[Z]
		0,50	48 B	64 B	64 B	80 B					
		0,60	48 B	48 B	64 B	80 B	80 B				
		0,80	40 B	48 B	64 B	64 B	80 B				
		1,00	40 B	48 B	48 B	64 B	80 B	80 B	100 B		
		1,20	40 B	40 B	48 B	64 B	64 B	80 B	100 B		
		1,60	32 B	40 B	48 B	48 B	64 B	80 B	80 B	100 B	
		2,00	32 B	40 B	40 B	48 B	64 B	64 B	80 B	100 B	
		2,50	32 B	32 B	40 B	48 B	48 B	64 B	80 B	80 B	100 B
		3,00	24 B	32 B	40 B	40 B	48 B	64 B	64 B	80 B	100 B
		4,00	24 B	32 B	32 B	40 B	48 B	48 B	64 B	80 B	80 B
		5,00	24 B	24 B	32 B	40 B	40 B	48 B	64 B	64 B	80 B
		6,00	20 B	24 B	32 B	32 B	40 B	48 B	48 B	64 B	80 B

HSS-DMo5 (M2) – DIN 1.3343 – JIS SKH51 – “SILVERFACE”

- ▶ Acciaio super-rapido al wolframio-molibdeno
- ▶ High Speed tungsten-molybdenum steel
- ▶ Hochleistungsschnellstahl mit Wolfram und Molybdän

HSS-Co5 (M35) – DIN 1.3243 – JIS SKH55 – HSS-E – “DURABLE”

- ▶ Acciaio super-rapido al wolframio-molibdeno-cobalto
- ▶ High Speed tungsten-molybdenum-cobalt steel
- ▶ Hochleistungsschnellstahl mit Wolfram und Molybdän und Cobalt

DIN 1838	BW	Ø [mm]	50	63	80	100	125
		Mozzo / Hub / Nabe [dt]	-	-	36	40	40
		Foro / Bore / Bohrung [d]	13	16	22	22	22
		Spessore Thickness Stärke B [mm]	[Z]	[Z]	[Z]	[Z]	[Z]
		1,00	40 Bw	48 Bw	48 Bw	64 Bw	80 Bw
		1,20	40 Bw	40 Bw	48 Bw	64 Bw	64 Bw
		1,60	32 Bw	40 Bw	48 Bw	48 Bw	64 Bw
		2,00	32 Bw	40 Bw	40 Bw	48 Bw	64 Bw
		2,50	32 Bw	32 Bw	40 Bw	48 Bw	48 Bw
		3,00	24 Bw	32 Bw	40 Bw	40 Bw	48 Bw
		4,00	24 Bw	32 Bw	32 Bw	40 Bw	48 Bw
		5,00	24 Bw	24 Bw	32 Bw	40 Bw	40 Bw
		6,00	20 Bw	24 Bw	32 Bw	32 Bw	40 Bw

DIN 1838	C	Ø [mm]	160	200	250	315
		Mozzo / Hub / Nabe [dt]	63	63	63	80
		Foro / Bore / Bohrung [d]	32	32	32	40
		Spessore Thickness Stärke B [mm]	[Z]	[Z]	[Z]	[Z]
		1,00	80 C	100 C		
		1,20	80 C	100 C		
		1,60	80 C	80 C	100 C	
		2,00	64 C	80 C	100 C	
		2,50	64 C	80 C	80 C	100 C
		3,00	64 C	64 C	80 C	100 C
		4,00	48 C	64 C	80 C	80 C
		5,00	48 C	64 C	64 C	80 C
		6,00	48 C	48 C	64 C	80 C



Seghe circolari DIN in HSS / DIN circular saw blades in HSS / DIN Metallkreissägeblätter aus HSS

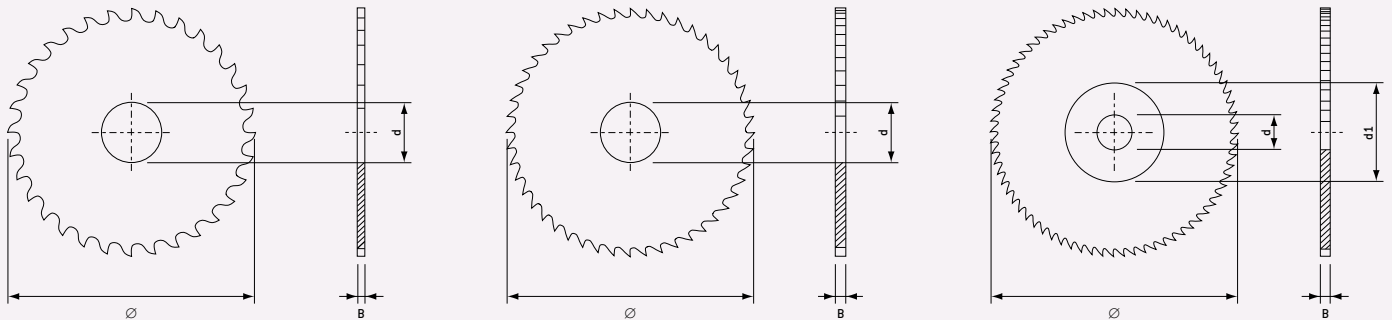

Ø [mm]	Spessore Thickness Stärke B [mm]	Foro centrale Central bore Bohrung d [mm]	Mozzo Hub Nabe d1 [mm]	Z	SEGHE PER TAGLIO ORBITALE TUBI SAWS FOR TUBE CUTTING KREISSÄGEBLÄTTER FÜR ORBITALES ROHRSAGEN		
					"SILVERFACE"	"DURABLE"	"EXTRA DURABLE"
63	1,6	16	36	44 BW	X	X	X
	1,6	16	36	80 BW	X	X	X
	1,6	16	44	64 BW	X	X	X
	1,6	16	44	100 BW	X	X	X
68	1,6	16	44	44 BW	X	X	X
	1,6	16	44	64 BW	X	X	X
	1,6	16	44	72 BW	X	X	X
	1,6	16	44	84 BW	X	X	X
75	1,6	16	42	32 BW	X	X	X
	1,6	16	42	44 BW	X	X	X
	1,6	16	42	76 BW	X	X	X
	2,0	16	44	32 BW	X	X	X
80	1,6	16	42	40 BW	X	X	X
	1,6	16	42	64 BW	X	X	X
	1,6	16	42	80 BW	X	X	X
	2,0	16	44	34 BW	X	X	X
	2,0	16	44	54 BW	X	X	X
	2,0	16	44	80 BW	X	X	X

Rivestimenti / PVD Coatings / PVD Beschichtungen



Rivestimento classico di tecnologia obsoleta, utilizzato per il taglio di acciai dolci. Non può essere usato nel taglio di Rame, Ottone, Bronzo.
 Classic old technology coating used to cut soft steels. Can't be used on Copper, Brass, Bronze.
 Standard Beschichtung, geeignet zum Schneiden von weichen Stählen. Es kann nicht verwendet werden zum Schneiden von Kupfer, Messing und Bronze.



Miglior rivestimento per il taglio in presenza di olio spray. Non può essere usato per il taglio di acciai dolci con abbondante lubrificante refrigerante.
 Best coating to cut with oil mist. Can't be used to cut soft steels with abundant coolant.
 Beste Beschichtung zum Schneiden von harten Stählen unter Verwendung von Öl-Spray. Nicht geeignet für weiche Stähle.

TIPI DI RIVESTIMENTI / COATINGS / BESCHICHTUNG	SILVERFACE	GOLDFACE	EXTRA DURABLE
Durezza Superficiale / Surface Hardness / Oberflächenhärte [Hv]	900	2400	3500
Temperatura di ossidazione / Oxidation temperature / Oxidationstemperatur [°]	350	600	800
Coefficiente di attrito / Friction Coefficient / Reibungskoeffizient	0,55	0,55	0,60
Colore / Color / Farbe	SILVER	GOLD	BLUE